

GHH RAND

CG600DP – Oil Free Screw Compressor with Diesel Engine

Compressed air solutions for the pneumatic conveying
of dry bulk material



GHH RAND

CG600 DP Belt Drive „Non-EU“

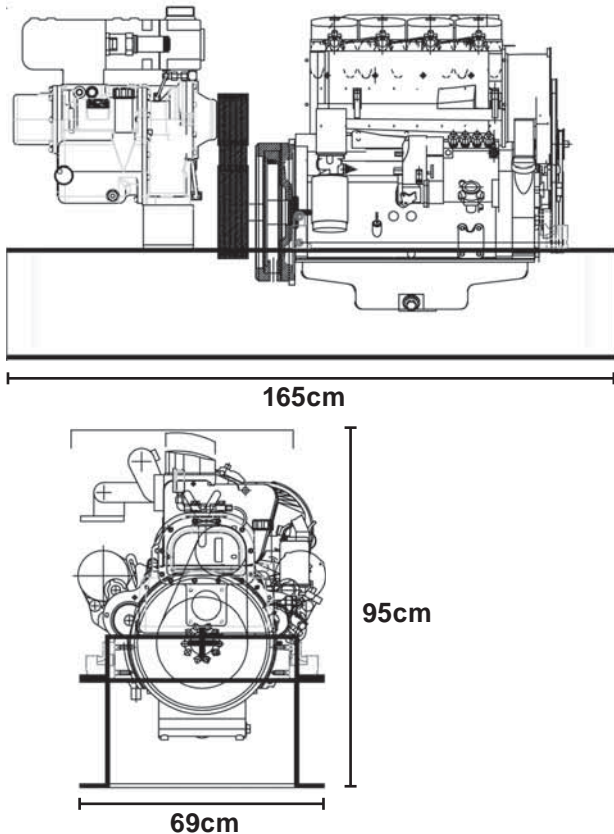

Compressor for the dry bulk Tanker Industry

For over 50 years, GHH RAND have been supplying Oil Free Screw Compressors into the Dry Bulk “Silo” Tanker Market. Manufactured in Germany and supported by our Worldwide SILU® Partner Network, GHH RAND are pleased to offer our latest development, which brings together proven and reliable technologies for both the diesel engine and the screw compressor in a rigid and robust package design.

Technical Data

- Suction volume 550 m³/h @ 2.0 bar (g) (535 m³/h @ 2.5 bar (g))

Scope of Supply

- GHH RAND **SILU® CG80** oil free screw compressor
- **Discharge silencer**, safety pressure relief and non-return valve
- High-performance inlet filter
- 10 liters of Silol lubricant
- Air cooled **Deutz Diesel F4L912** (pre-set to 2,000 rpm)
- Integral 64 liter fuel tank, complete with fuel gauge
- Compact **steel base frame**, engineered for strength and durability
- 2 ½ " discharge connection with blanking cap and chain
- Anti-vibration mounting
- Key start control box rated to IP55
- Provision for battery mounting
- Belt drive
- Weight 720 kg

GHH RAND Schraubenkompressoren GmbH

Customer Center Tanker Solutions

Max-Planck-Ring 27 • 46049 Oberhausen • Germany
Phone +49 (0) 208 9994-0 • Fax -179
info_ghh-rand@irco.com • www.ghhrand.com