

# GHH RAND

## *CG600 EP Light – Oil-free Screw Compressor Block with Electric Motor*

Compressed Air Solutions for the pneumatic discharge  
of bulk material.

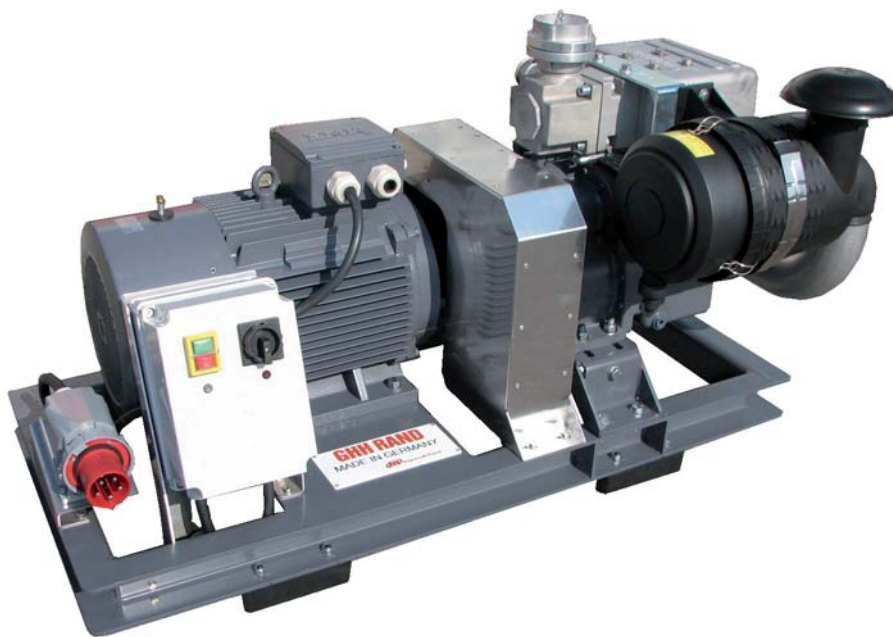

# GHH RAND

## CG600 EP Light Belt Drive “Non-EU”

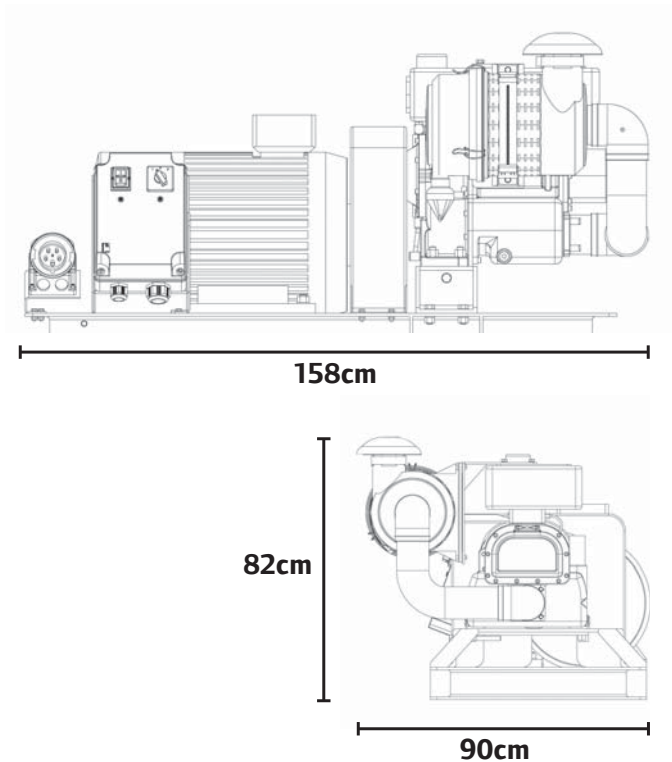

### Compressor for the Dry Bulk Tanker Industry

For over 50 years GHH RAND have been supplying Oil Free Screw Compressors into the Dry Bulk “Silo” Tanker Market. Manufactured in Germany and supported by our Worldwide SILU® Partner Network, GHH RAND are pleased to offer our latest development, which brings together proven and reliable technologies for both the electric motor and the screw compressor in a rigid and robust package design.

#### Technical Data

- Suction volume 470 m<sup>3</sup>/h at 2.0 bar (g)

#### Scope of Supply

- GHH RAND **SILU® CG80** oil-free screw compressor
- **Discharge silencer**, safety pressure relief and non-return valve
- High-performance inlet filter
- 10 litres of Silol lubricant
- Three-phase AC motor type B3, 30 kW power output (400 V / Δ / 50 Hz)
- Motor speed 3000 min<sup>-1</sup>, protection class IP55
- Mounted on a robust, powder-coated **steel frame**
- Bearing of frame on anti-vibration buffers
- Suited for food and chemical applications due to plastic air filter and reactive silencer

#### Options

- Integrated oil cooler for continuous duty
- CEE plug
- Bearing of frame on rubber to metal buffers

### GHH RAND Schraubenkompressoren GmbH

#### Customer Center Tanker Solutions

Max-Planck-Ring 27 · 46049 Oberhausen · Germany  
Phone +49 (0) 208 9994-0 · Fax -179  
info\_ghh-rand@irco.com · www.ghhrand.com